



TOWN OF AMHERST
Fire Safety Division

5583 Main St – Lower Level
Amherst, New York 14221

Office (716) 631-7140

Fax (716) 631-7192

Email: firesafety@amherst.ny.us

Smoke Alarms - Residential

This is to provide guidance for the requirements and maintenance of smoke alarms in residential dwelling units in compliance with the Residential Code of New York State and NFPA 72.

Purpose

Smoke alarms and heat detectors that are properly installed and maintained play a vital role in reducing fire deaths and injuries. Smoke alarms and heat detectors save lives. If there is a fire in your home, smoke spreads fast and you need smoke alarms to give you time to get out. When asleep, the occupants of residential buildings will usually be unaware of a fire, and the fire will have an opportunity to spread before being detected. A majority of fire deaths occurring in residential buildings have occurred because of this delay in detection. It is for this reason that the code requires smoke alarms.

References

2020 Residential Code of New York State; NFPA 72

Type of work being done

1. **New Construction**

a. Smoke alarms shall be provided in dwelling units. Heat detection shall be provide in new attached garages.

2. **Alterations, repairs and additions**

a. Where alterations, repairs or additions requiring a permit occur, or where one or more sleeping rooms are added or created in existing dwellings, the individual dwelling unit shall be equipped with smoke alarms located as required for new dwellings.

Location of Smoke Alarms & Heat Detectors

1. **Smoke alarms and heat detectors shall be installed in the following locations:**

a. In each sleeping room.

b. Outside each separate sleeping area in the immediate vicinity of the bedrooms.

c. On each additional story of the dwelling, including basements and habitable attics and not including crawl spaces and uninhabitable attics. In dwellings or dwelling units with split levels and without an intervening door between the adjacent levels, a smoke alarm installed on the upper level shall suffice for the adjacent lower level provided that the lower level is less than one full story below the upper level.

d. Smoke alarms shall be installed not less than 3 feet (914 mm) horizontally from the door or opening of a bathroom that contains a bathtub or shower unless this would prevent placement of a smoke alarm required by those listed above.

e. Heat detectors shall be in new attached garages. Recommended for existing attached garages.

2. **Additional alarms per National Fire Protection Agency**

a. For extra protection, NFPA suggests installing alarms in dining rooms, furnace rooms, utility rooms and hallways.

3. **Locations not recommended for smoke alarms**

- a. Smoke alarms are not recommended for bathrooms or garages - where steam or exhaust fumes could set off false alarms - or for attics and other unheated spaces where humidity and temperature changes might affect an alarms operation.
4. **Installation near cooking appliances** (see type of smoke alarms below)
- a. Smoke alarms shall not be installed in the following locations unless this would prevent placement of a smoke alarm in a required location
 - i. Ionization smoke alarms shall not be installed less than 20 feet (6096 mm) horizontally from a permanently installed cooking appliance.
 - ii. Ionization smoke alarms with an alarm-silencing switch shall not be installed less than 10 feet (3048 mm) horizontally from a permanently installed cooking appliance.
 - iii. Photoelectric smoke alarms shall not be installed less than 6 feet (1828 mm) horizontally from a permanently installed cooking appliance.

Type of Smoke Alarms

1. **Combination Alarms**

- a. Combination smoke and carbon monoxide alarms shall be permitted to be used in lieu of smoke alarms.

2. **Ionization smoke detection**

- a. Generally more responsive to flaming fires.
- b. How they work: Ionization-type smoke alarms have a small amount of radioactive material between two electrically charged plates, which ionizes the air and causes current to flow between the plates. When smoke enters the chamber, it disrupts the flow of ions, thus reducing the flow of current and activating the alarm.

3. **Photoelectric smoke detection**

- a. Generally more responsive to fires that begin with a long period of smoldering (called "smoldering fires").
- b. How they work: Photoelectric-type alarms aim a light source into a sensing chamber at an angle away from the sensor. Smoke enters the chamber, reflecting light onto the light sensor; triggering the alarm.

*** NOTE: Smoke Alarms shall be listed and labeled as complying with UL 217.**

Combination Alarms shall be listed and labeled as complying with UL 2034 and UL 217.

Power Source

1. **Interconnection**

- a. Where more than one smoke alarm is required to be installed within an individual dwelling unit in accordance with "Location of Smoke Alarms", as listed above, the alarm devices shall be interconnected in such a manner that the actuation of one alarm will activate all of the alarms in the individual dwelling unit.
- b. Physical interconnection of smoke alarms shall not be required where listed wireless alarms are installed and all alarms sound upon activation of one alarm.
- c. Interconnection of smoke alarms in existing areas shall not be required where alterations or repairs do not result in removal of interior wall or ceiling finishes exposing the structure, unless there is an attic, crawl space or basement available that could provide access for interconnection without the removal of interior finishes.

2. **Power**

- a. Smoke alarms shall receive their primary power from the building wiring where such wiring is served from a commercial source and, where primary power is interrupted, shall receive power from a battery. Wiring shall be permanent and without a disconnecting switch other than those required for overcurrent protection.

- b. Smoke alarms installed in accordance with "Type of work being done", as listed above, shall be permitted to be battery powered. Battery powered alarms shall have a 10 year sealed battery. *Removable batteries are not permitted in installations of smoke alarms.*

Where to install

Since smoke rises, mount alarm high on the wall or on the ceiling. Wall-mounted units should be mounted so that the top of the alarm is 4 to 12 inches from the ceiling. A ceiling-mounted alarm should be attached at least 4 inches from the nearest wall. In a room with a pitched ceiling, mount the alarm at or near the ceiling's highest point.

In stairways with no doors at the top or bottom, position smoke alarms anywhere in the path of smoke moving up the stairs. But always position smoke alarms at the bottom of closed stairways, such as those leading to the basement, because dead air trapped near the door at the top of a stairway could prevent smoke from reaching an alarm located at the top.

Do not install a smoke alarm too close to a window, door, or forced-air register where drafts could interfere with the alarm's operation.

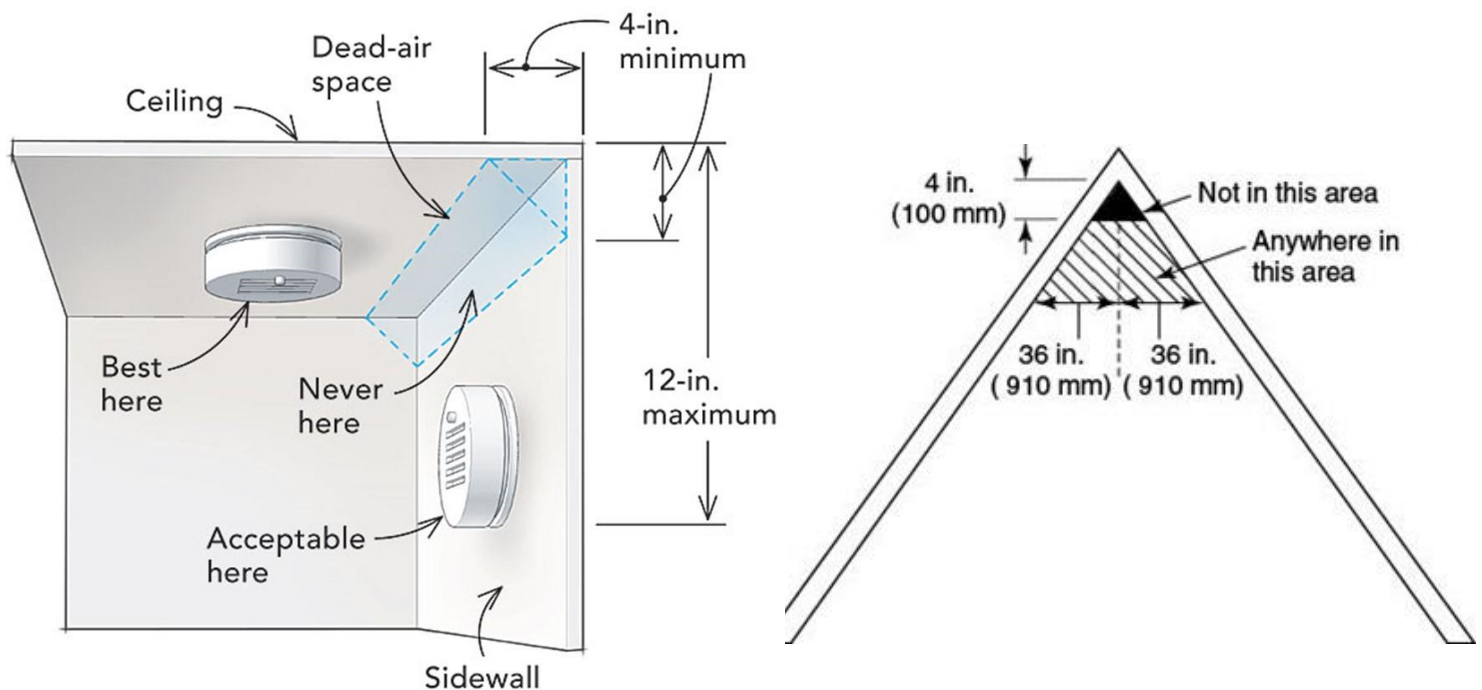

Maintenance

- Only a functioning smoke alarm can protect you.
- Never disable an alarm by "borrowing" its battery for another use.
- Never remove a battery because the alarm is annoying.
- Following manufacturer's instructions, test all your smoke alarms monthly and install new batteries at least once a year. A good reminder is when you change your clocks in the spring or fall: change your clock, change your battery.
- Clean your smoke alarms using a vacuum cleaner without removing the alarms cover.
- Never paint a smoke alarm.
- Smoke alarms don't last forever. Replace any smoke alarm that is more than 10 years old